



origin  
DOORS AND WINDOWS

# Bi-fold Doors

# Installation Guide



## General notes

1. THIS PRODUCT HAS BEEN TESTED EVALUATED AND DESIGNED TO THE DESIGN PRESSURE(S) STATED HEREIN AS FOLLOWS.
  - 1.1 IN COMPLIANCE WITH THE 2010 FLORIDA BUILDING CODE – SECTIONS 1606.1.2, 1626, 1715.5.2, 1715.5.3, 1715.5.4 AND 2411.3.
  - 1.2. IN COMPLIANCE WITH THE 2010 FLORIDA RESIDENTIAL CODE – SECTIONS R301.2.1.2, R612.6, R612.8, R612.10, R4403.16 AND R4410.2.3.
  - 1.3 PERFORMANCE STANDARDS
    - 1.3.1 TAS 201
    - 1.3.2 TAS 202
    - 1.3.3 TAS 203
2. THIS PRODUCTS DETAILS CONTAINED HEREIN ARE BASED UPON SIGNED AND SEALED TEST REPORT NO.D0973.01-401-18 AND ASSOCIATED LABORATORY DRAWINGS BY ARCHITECTURAL TESTING, INC.
3. THIS PRODUCT EVALUATION DOCUMENT IS FOR USE IN THE HIGH VELOCITY HURRICANE ZONE (HVHZ).
4. ADEQUACY OF THE EXISTING STRUCTURAL CONCRETE/MASONRY, 2X FRAMING AND METAL FRAMING SUBSTRATES AS A MAIN WIND FORCE RESISTIG SYSTEM CAPABLE OF WITHSTANDING AND TRANSFERRING APPLIED PRODUCT LOADS TO THE FOUNDATION IS THE RESPONSIBILITY OF THE LICENSED PROFESSIONAL ENGINEER OR REGISTERED ARCHITECT ACTING AS THE DESIGN PROFESSIONAL OF RECORD FOR THE PROJECT OF INSTALLATION.
5. 1X AND 2X BUCKS (WHEN USED) SHALL BE DESIGNED AND ANCHORED TO PROPERLY TRANSFER ALL LOADS TO THE STRUCTURE. BUCK DESIGN AND INSTALLATION IS THE RESPONSIBILITY OF THE LICENSED PROFESSIONAL ENGINEER OR REGISTERED ARCHITECT ACTING AS THE DESIGN PROFESSIONAL OF RECORD FOR THE PROJECT OF INSTALLATION.
6. AN APPROVED IMPACT PROTECTIVE SYSTEM IS NOT REQUIRED ON THIS PRODUCT WHEN INSTALLED IN AREAS REQUIRING WIND BRONE DEBRIS PROTECTION THIS INCLUDES THE HIGH VELOCITY WIND ZONE (HVHZ).
7. SITE CONDITIONS NOT COVERED IN THIS PRODUCT EVALUATION DOCUMENT ARE SUBJECT TO ADDITIONAL ENGINEERING ANALYSIS BY A LICENSED PROFESSIONAL ENGINEER OR REGISTERED ARCHITECT AS REQUIRED BY THE AUTHORITY HAVING JURISDICTION.
8. MATERIALS
  - 8.1 DOOR FRAME MATERIAL: 6063-T5
  - 8.2 GLAZING GASKET: MEETS ASTM E 2203-2 IN ACCORDANCE WITH THE 2010 FBC, SECTION 2411.3.4 AND 2010 FRC, SECTION R4410.2.3.4.
  - 8.3 GLAZING INTERLAYER: DUPONT SG INTERPLAYER PER MD NOA NO. 11-0624.02.
  - 8.4 THERMAL BREAK MATERIAL: POLYAMIDE BY TECHNOFORM OR CORTIZO.
9. LOCKING HARDWARE
  - 9.1 MILLENCO MULTI-POINT LOCK SYSTEM WITH LATCH AND DEADBOLT TWO HOOKS WITH TOP AND BOTTOM FLUSH BOLTS.
10. GLASS MEETS THE REQUIREMENTS OF ASTM E1300-09A.
11. DESIGNATIONS "X" STANDS FOR OPERABLE LEAF (PANEL).
12. IN ACCORDANCE WITH THE 2010 FBC, SECTION 2003.8.4 DISSIMILAR METALS INCLUDING FASTENERS THAT MAY COME INTO CONTACT WITH ALUMINIUM FRAMING SHALL HAVE BEEN PROTECTED AS DEFINED IN SECTION 2003.8.4.2.
13. IN ACCORDANCE WITH THE 2010 FBC, SECTION 2411.3.3.3, WOOD BUCKS SHALL HAVE BEEN PRESERVATIVE TREATED OR SHALL BE OF A DURABLE SPECIES AS DEFINED IN SECTION 2326.2.
14. THESE DRAWINGS CERTIFY THE DOOR INSTALLATION ONLY. WATER RESISTIVE SEALING OF THE INSTALLED DOOR IS NOT PART OF THIS INSTALLATION CERTIFICATION, THAT RESPONSIBILITY SHALL BE THAT OF THE SPECIFIER AND/OR THE INSTALLER.
15. FOLDING DOOR AND LEAF PANEL CONFIGURATIONS:
  - 15.1 THE PANEL DOORS WHERE TESTED WITH 8 LEAFS FOLDING TO THE INSIDE (8 + 0 CONFIGURATION), FIVE LEAFS LEFT/3 LEAFS RIGHT FOLDING TO THE INSIDE (5 + 3 CONFIGURATION) AND GIVE LEAFS LEFT/3 LEAFS RIGHT FOLDING TO THE OUTSIDE (5 + 3 CONFIGURATION). THIS TESTING COVERED ALL STILE CONDITIONS AND ALLOWS FOR FRAME LENGTHS EXCEEDING THOSE USED IN TESTING AND SHOWN IN THIS INSTALLATION DRAWING. THE FOLLOWING LIMITATIONS EXIST ON FRAME AND LEAF SIZING.
    - 15.1.1 FRAME SIZE WILL NOT EXCEED 101-7/8" IN HEIGHT.
    - 15.1.2 LEAFS (PANELS) SHALL NOT EXCEED THE FOLLOWING:
      - 15.1.2.1 ACTIVE AND INACTIVE LEAFS: 36-3/4" X 96"
      - 15.1.2.2 SLAVE LEAFS: 36" X 96"
    - 15.2 OTHER LEAF CONFIGURATIONS ARE ALLOWED INCLUDING:
      - 15.2.1 VARYING LEAF QUANTITIES CONNECTED ON LEFT AND RIGHT.
      - 15.2.2 OVERALL QUANTITY OF LEAFS, AND
      - 15.2.3 OPENING TO INSIDE OR TO OUTSIDE
    - 15.3 SILL OPTIONS
      - 15.3.1 BOM ITEM NO. 22 AND 23 CAN BE USED INTERCHANGEABILITY.
      - 15.3.2 SEE SHEETS 8 AND 9 FOR INSTALLATION DETAILS.

## Components box

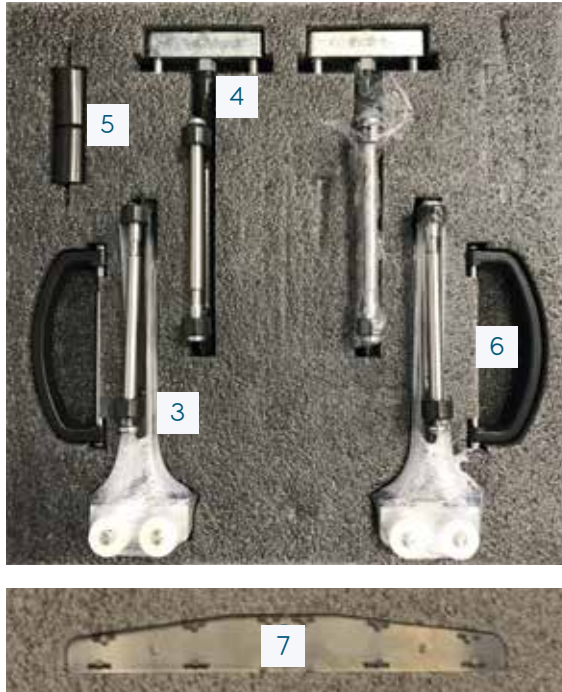

## Contents

- ▶ 1. Fixing plugs
- ▶ 2. Wedge gasket
- ▶ 3. Bottom trolley
- ▶ 4. Top trolley
- ▶ 5. Magnetic bumpers
- ▶ 6. D-handle
- ▶ 7. Sill end cap (if applicable)
- ▶ 8. Hafli handle

# 1. Tools list

**1.1.** Fixing kit which includes a selection of shims 1mm–6mm and 4mm glazing shims.

- ▶ Minimum of 8" long - 3/16" drill bit for concrete install (not needed for wood)
- ▶ Impact and regular battery screwdriver
- ▶ Long straight edge
- ▶ Long spirit level
- ▶ String line
- ▶ Measuring staff
- ▶ PH 2 hand screw driver
- ▶ 5/32" (4mm) Allen key
- ▶ Flat bar
- ▶ Plastic/ rubber hammer
- ▶ Gasket sheers
- ▶ Non or low expanding foam
- ▶ Silicone & silicone gun
- ▶ Glass suction cups (optional)
- ▶ 9/64" Drill Bit (for magnetic bumpers)

## Note

If it is necessary to pack the outer frame by more than 1/4", a solid plastic or hardwood shim should be used. **\*You can not shim more than 1/4" in Florida.**

## 2. Preparation

- ▶ **2.1.** Measure the opening and check it fits with all measurements on your Origin paperwork.
- ▶ **2.2.** Carefully unpack the track and jambs.
- ▶ **2.3.** Spaced next to pre-drilled holes, place the correct shims along the length of the opening, creating a level, well supported platform for the track / sill to sit.
- ▶ **2.4.** If concrete bottom of opening, pre-drill all fixing holes and mark the position of shims. Remove and clean both the opening and sill.
- ▶ **2.5.** Secure shims down by using silicone sealant and then run sealant over and in between the shims and pre-drilled holes.

### 3. Sub Sill (if no sill, move to step 4.)

- ▶ **3.1.** Using an appropriate silicone sealant, fill the ends of the sill section and install the end caps.
- ▶ **3.2.** Run a bead of sealant across the layered shims
- ▶ **3.3.** Place the sill on the prepared shims in the opening.
- ▶ **3.4.** Using a string line, make sure the sill does not bow.

## 4. Outer frame

- ▶ **4.1.** Joining tracks (if applicable - oversized jobs and corner posts).
  - ▶ **4.1.1.** All joints in the tracks are pre-made in the factory and separated for transport. When joints are re-made, we recommend clear silicone to seal the joint.
  - ▶ **4.2.** Carefully remove the gasket from each end of the top and bottom track by approximately 12”.
  - ▶ **4.3.** Where possible, lay out the tracks and jambs in the correct positions with all labels facing up, being careful not to scratch the powder coat.
  - ▶ **4.4.** Position the jambs into the tracks using the connectors provided as shown in FIG 4A.
  - ▶ **4.5.** Using a rubber mallet, gently tap the jambs in to the track as shown in FIG 4B.
- NOTE:** If more than a tap is needed, the connectors are not aligned with the tracks.
- ▶ **4.6.** If applicable, using silicone, seal along the two ends and back lip of the sub-sill where the bottom track will sit.
  - ▶ **4.7.** Install the outer frame and insert frame packers above the top track at each end, compressing tracks, jambs and sill (if fitted), together closing all unwanted gaps and temporarily holding the frame in position as shown in FIG 4C.
  - ▶ **4.8.** Make sure the bottom track is pushed up against the lip at the back of the sub-sill (if fitted) and is central in the opening.



FIG 4A



FIG 4B



FIG 4C



## 5. Fixing the outer frame

► **5.1.** Fix the bottom track as shown in FIG 5A or B (through pre-drilled holes).

► **5.2.** Align the bottom of the jambs with the end of the bottom track. Using shims between the jamb packers and the wall, plumb the jambs in all directions and anchor into position as shown in FIG 5C through pre-drilled holes.

► **5.3.** Align the end of the top track with the top of the jamb as shown in FIG 5D.

► **5.4.** Install the first anchor into the top track next to the jamb as shown in FIG 5E, being careful not to lift the track from the top of the jamb when the anchor is tightened. (through pre-drilled holes)

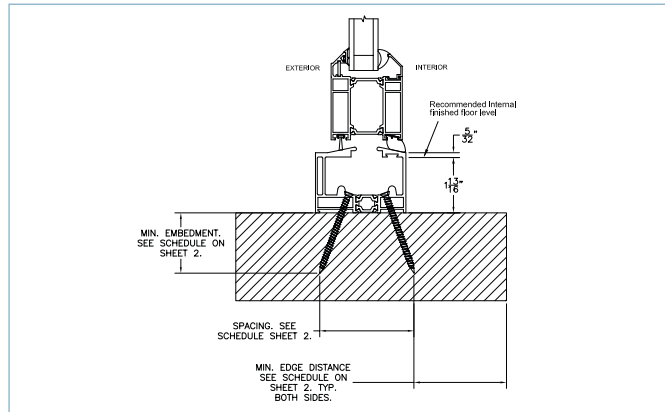

FIG 5A

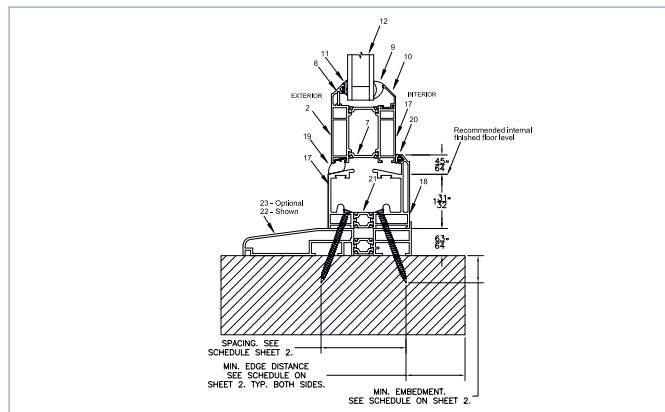

FIG 5B

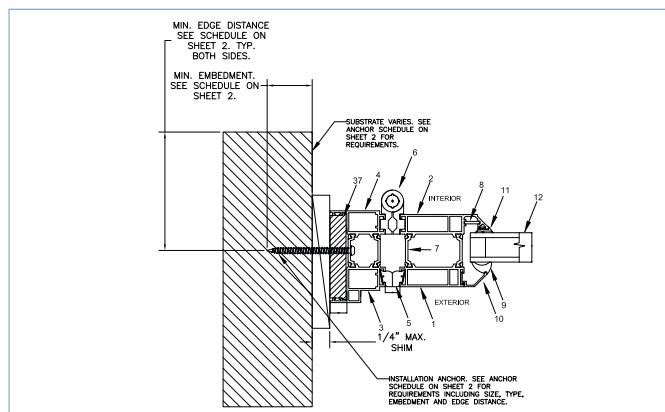

FIG 5C

5. Fixing the outer frame continued

▶ **5.5.** Using the string line and measuring staff, make sure the track does not bow inside to out, or up and down, as shown in FIG 5F.

▶ **5.6.** Install the remaining anchors into the top track as shown in FIG 5E being careful not to bow or twist the track, (through pre-drilled holes).

▶ **5.7.** Trim and reinstall the track gasket.



FIG 5D

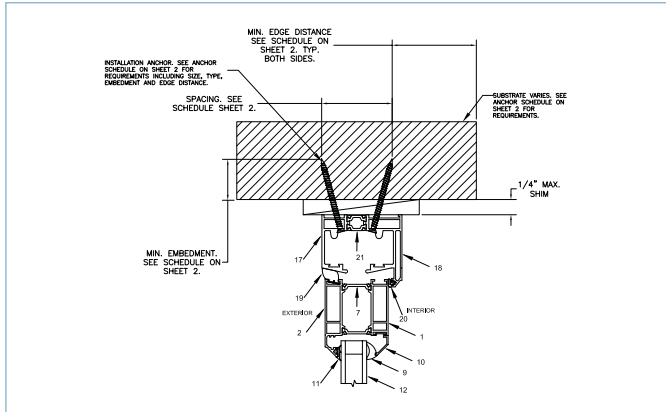

FIG 5E



FIG 5F

## 6. Top and bottom fork

- ▶ **6.1.** Remove the bottom carriage and fork assembly from its packaging, and using a (Blue 5mm) shim, check the ride height of the fork is set correctly as shown in FIG 6A.
- ▶ **6.2.** Locate the fork pins and remove from the trolleys.
- ▶ **6.3.** Place the bottom carriage and fork assembly into the bottom track as shown in FIG 6B. The fork should point to the outside if the doors are open out, and inside if the doors open in. Repeat this process until all bottom carriage assemblies have been installed.
- ▶ **6.4.** Install all top fork guide wheels and move down the track to the opposite end. The thicker side of the wheel should be on top as shown in FIG 6C.
- ▶ **6.5.** Insert the top fork between two guide wheels and lower down to locate the pins into them from above, as shown in FIG 6D&E. Repeat this process until all top forks are installed.



FIG 6A



FIG 6B



FIG 6D



FIG 6E

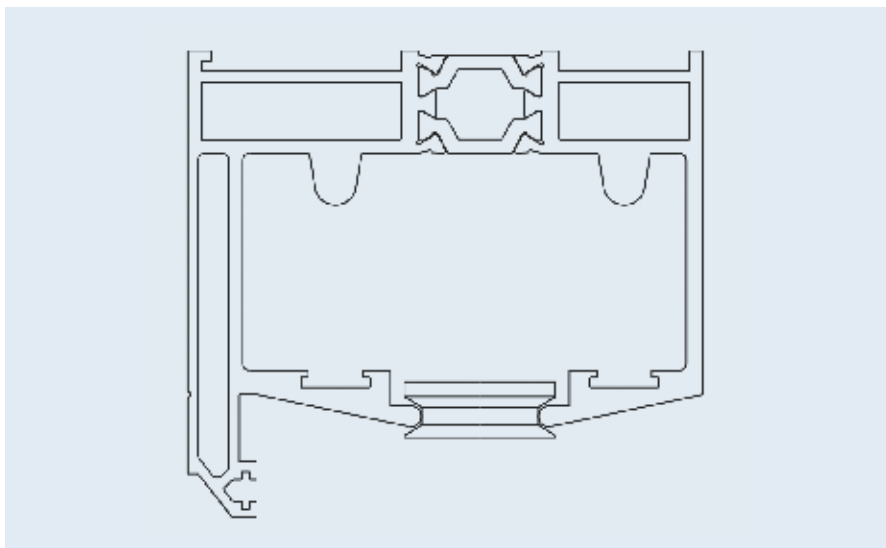

FIG 6C

## 7. Door leaves

- ▶ **7.1.** Locate spare hinge pins in zip lock bag in component box.
- ▶ **7.2.** Locate the door to be connected to the hinge jamb, this will be marked on the label with an X showing its position when viewed from the outside.
- ▶ **7.3.** Hang the first door on the hinge jamb as shown in FIG 7A&B with the label at the top and facing out.
- ▶ **7.4.** Hang the second door onto the hinges of the first door, again with the label at the top and facing out as shown in FIG 7C. If out swing, skip middle pin (D handle).
- ▶ **7.5.** Close the two doors across the track and lock into place with the slave handle, being careful not to scratch the track as the doors cross it.
- ▶ **7.6.** Hang the third door onto the center hinge and insert a screwdriver through the top hinge; this will support the door while the forks are located as seen in FIG 7D.
- ▶ **7.7.** With the third door completely open, place the bottom fork around the bottom hinge between the second and third doors. Doors may need to be lifted a touch to be able to locate the fork around the hinge.
- ▶ **7.8.** Remove a screw from pin and locate flat spot on the pin as well as the inside of the trolley fork. Line these up and push (tap) the pin through, being careful to align the hinge and fork. Check one more time for flat spots aligning before pushing the pin down to be flush on top.
- ▶ **7.9.** Install the screw into the fork pin and using a T30 Allen Key (provided), fully tighten.
- ▶ **7.10.** Remove the screwdriver from the top hinge and place the top fork around the hinge.
- ▶ **7.11.** Insert the second fork pin bolt as described in points 7.8. and 7.9 (inserting from below).
- ▶ **7.13.** Repeat steps 7.1 to 7.12 until all door leaves are installed.

### Note

When closing the master/lead door for the first time, ensure that there are no obstacles that are preventing the door from closing smoothly. If contact occurs, adjust the doors as described in section 14.



FIG 7A



FIG 7B



FIG 7C



FIG 7D

## 8. False mullion

(even number of doors moving in the same direction only)

- ▶ **8.1.** Remove the center hinge from the mullion.
- ▶ **8.2.** With the last pair of doors at 90° to the tracks, locate the top and bottom forks around the hinges.
- ▶ **8.3.** Position the mullion into the tracks and slide along to mate with the hinges and forks as shown in FIG 8A.
- ▶ **8.4.** Insert both top and bottom fork pins as described in the previous section.
- ▶ **8.5.** Replace the center hinge and screws being careful not to cross thread the screws when re-installed.



FIG 8A

## 9. Handles

### D-handles (open out only)

- ▶ **9.1.** Position the D-handle over the center hinge above the slave handle.
- ▶ **9.2.** Fix the handle with the same pin (provided with handle) used for trolleys (flat spots and just one screw again).

### D-handle



### Hafi handles



(Style 253/280)



(Style 251/280)



(Style 301/280)



(Style 303/280)

### Long Back Plate Lever/ Lever Handles

- ▶ **9.3.** Remove the screws from the lever handle, allowing the two halves to be separated.
- ▶ **9.4.** Insert the spindle and a return spring (if supplied) into the outer part of the handle. (The outer handle will have the thread for the handle screws).
- ▶ **9.5.** Making sure the lever is across the glass, insert the spindle into the lock.
- ▶ **9.6.** Locate the handle around the barrel and flush against the door.
- ▶ **9.7.** Install the internal part of the handle and second return spring (if supplied), again with the lever across the glass.

**NOTE:** Always keep a hand on the external handle to prevent damage.

**NOTE:** It may be necessary to slacken the retaining screw on the barrel to help alignment. Always retighten.

- ▶ **9.8.** Install the two screws and carefully tighten with a hand screwdriver only.

### Hafi Stainless Steel Handles (separate handle and barrel)

- ▶ **9.9.** Locate the handles and 4 no. 20mm x M5 screws from the components box.
  - ▶ **9.10.** Remove the escutcheons from both handles.
  - ▶ **9.11.** Insert the spindle into one lever and snug the grub screw using a 1/8" Allen key.
  - ▶ **9.12.** Install the handle and spindle into the door with the lever across the glass.
  - ▶ **9.13.** Insert the 20mm x M5 screws and tighten using a PH 2 hand screwdriver only, being careful not to cross thread the screws..
  - ▶ **9.14.** Install the remaining lever onto the door and secure in place, as described in the previous step and nip the remaining grub screw.
  - ▶ **9.15.** Install both inner and outer escutcheons with the small cut out pointing down.
- NOTE:** It may be necessary to use a rubber mallet to gently tap the escutcheons fully into position.

## 10. Center hinge

(open in only)

- ▶ **10.1.** Open the doors and locate the missing center hinges (in the box inside marked bags).
- ▶ **10.2.** Making sure the two halves of the top and bottom hinges are together, install the center hinge, being careful not to cross thread the screws.

**NOTE:** All hinges and screws will be found in the components box.

## Helpful hint

Using suction cups for handling glass makes glazing easier.

## 11. Glazing the doors

- ▶ **11.1.** Close all doors and fully engage the locks.
- ▶ **11.2.** Starting with the door next to the hinge jamb, carefully remove the 4 glazing beads.
- ▶ **11.3.** Place 2 wider yellow shim (4mm) in the bottom of the glazing chamber spaced approximately 2" in from each corner at 90° to the door, as shown in FIG 11A.
- ▶ **11.4.** Install the glass on to the packers, taking care not to pinch the gasket on the outside.
- ▶ **11.5.** Insert another wide yellow shim (4mm) to the side of the glass diagonally opposite the toe and heel plate about 2" up from the corner, making sure to support the inner and outer layers of the glass, as shown in FIG 11B.
- ▶ **11.6.** Using a glazing paddle at the bottom, lift the glass and turn the glazing shim which is diagonally opposite the toe and heel plate so it is in line with the glass, making sure inner and outer layers are supported, as shown in FIG 11B.
- ▶ **11.7.** Using the glazing paddle, lever the door up and place a wide black (2mm) glazing shim between the top of the glass and the toe and heel plate, making sure both inner and outer layers of the glass are supported.
- ▶ **11.8.** Remove the second glazing shim from under the glass and insert into the side, at the top of the door diagonally opposite the first two glazing shims, making sure inner and outer layers of glass are supported.
- ▶ **11.9.** Reinstall all 4 glazing beads starting with the top and bottom, care should be taken when installing the side beads so as not to scratch the top and bottom beads.
- ▶ **11.10.** Repeat steps 11.4 to 11.9 until all the glass is in place.



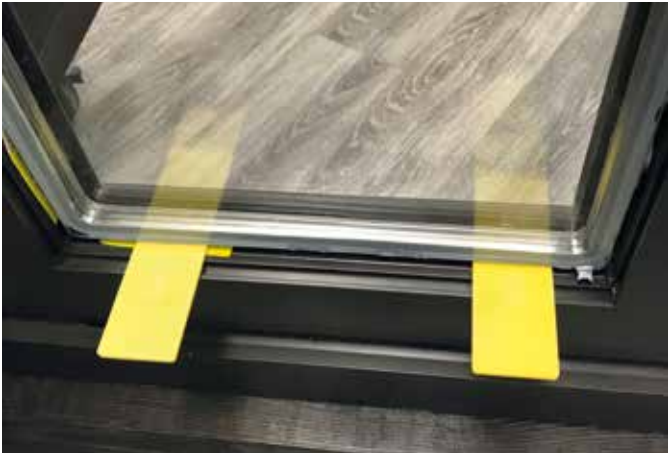

FIG 11A



FIG 11B



FIG 11C

## Notes

The shim positions will always be set by the location of the toe and heel plate and will be opposite to the adjoining door, as shown in FIG 11C.

If the glass is not square or stepped, it may be necessary to use a thinner packer between the glass and toe and heel plate.

(Refer to labels inside each door frame for placement of shims)

## 12. Installing the wedge gasket

- ▶ **12.1.** Starting with the bottom bead, use the glazing paddle to gently lever the bead away from the glass and into the correct position whilst lifting the side beads.
  - ▶ **12.2.** Place the gasket between the glass and bead with the concave side against the glass.
  - ▶ **12.3.** Feed the gasket behind the side bead until it stops and then continue along the bottom bead compressing the gasket towards the start point.
  - ▶ **12.4.** Repeat steps 12.1 to 12.3 with the top bead.
  - ▶ **12.5.** Cut a slight angle on the end of the gasket and insert behind the side bead pushing up to meet the top gasket. If cut right, the side gasket should look like it has been mitred to the top.
  - ▶ **12.6.** Continue to feed the gasket along the side bead, compressing towards the starting point.
  - ▶ **12.7.** Once the bottom is reached, cut the gasket approximately  $\frac{1}{4}$ " past the bottom gasket again with a slight angle to meet the bottom gasket.
  - ▶ **12.8.** Repeat steps 12.5 to 12.7 with the remaining side.
  - ▶ **12.9.** Repeat steps 12.1 to 12.8 with the remaining doors.
-

## 13. Toe and heel adjustment

- ▶ **13.1.** If adjustment is needed, you will find a toe and heel device in the top of each door.
- ▶ **13.2.** Open the doors so that you can get access to the toe and heel device at the top of the door. Using a 4mm Allen key, wind the bolt clockwise, this will cause the side of the door to rise.
- ▶ **13.3.** Close the doors and check that they run parallel and evenly to the top and bottom tracks. If they do not, then repeat as necessary.
- ▶ **13.4.** On doors not needing adjustment, make sure that each toe and heel plate is snug to the glass in each door, this will prevent the doors from settling over time.
- ▶ **13.5.** Do not tighten more than 3-4 full turns. If further adjustment is needed, it has to happen on the outer frame. Be sure to not over tighten toe and heel plates.

## 14. Adjustment

**NOTE:** All adjustment comes from the outer frame, hinges should not be moved under any circumstances.

### Tracks

- ▶ **14.1.** To check the top and bottom tracks are parallel, open all the door leaves completely.
- ▶ **14.2.** At this point, the pins in the center of the top guide wheel should be fairly flush with the visible face of the guide wheel, as shown in FIG 14A. Move the doors along the track while monitoring the pin position in the top guide wheels. If the top and bottom tracks are parallel, the visible pin should remain the same as at the start.
- ▶ **14.3.** If the visible pin decreases at any point, the top track will need re-shimming to raise it up at these points.
- ▶ **14.4.** If the visible pin increases at any point, the top track will need repacking to lower it at these points.

**NOTE:** The bottom track must be well supported and level for the description above to be correct.

### Jambs

- ▶ **14.5.** When the lead door is closed, there should be a visible gap of 4mm (wide yellow shim) between itself and the jamb or locking style, as shown in FIG 14B. Adjust as follows if necessary.
- ▶ **14.6.** Remove the three center anchors from one jamb.
- ▶ **14.7.** Remove the top anchor from that jamb.
- ▶ **14.8.** Re-shim the top of the jamb to give a 4mm (wide yellow shim) gap between the edge of the lead door and jamb at the top.
- ▶ **14.9.** Replace the anchor in the top of the jamb.
- ▶ **14.10.** Remove the bottom anchor from the jamb.
- ▶ **14.11.** Re-shim the bottom of the jamb to give a 4mm (wide yellow shim) gap between the edge of the lead door and jamb at the bottom.
- ▶ **14.12.** Replace the anchor in the bottom of the jamb.
- ▶ **14.13.** Shim and replace the remaining three anchors, maintaining the even 4mm (wide yellow shim) gap.



FIG 14A



FIG 14B

## 15. Magnetic bumper

- ▶ **15.1** Locate the magnetic bumper from the components box.
- ▶ **15.2** Open the lead door almost 180° until the handle is approximately 3/8" from the adjoining door and hold in position.
- ▶ **15.3** Position the complete magnetic keep up between the top of both doors and move along until it is wedged between them, as shown in FIG 15A.
- ▶ **15.4** Using a pencil, mark the magnet holder position on the lead door.
- ▶ **15.5** Close the lead door.
- ▶ **15.6** Return the magnet holder to your mark and move up or down to position in the centre of the door profile. The centre of the hole should be 1" down from the top of the door.
- ▶ **15.7** Using a 9/64" drill bit, mark the door through the hole in the magnet holder, as shown in FIG15B.
- ▶ **15.8** Remove the holder and using the 9/64" drill bit, drill a hole on the previously made mark.
- ▶ **15.9** Install the magnet and cover plate.
- ▶ **15.10** Place the two halves of the magnetic keep together.
- ▶ **15.11** Open the lead door against the adjoining door to locate the second half and mark with a pencil.
- ▶ **15.12** Fix in position as previously described.
- ▶ **15.13** Install cover plate.



FIG 15A

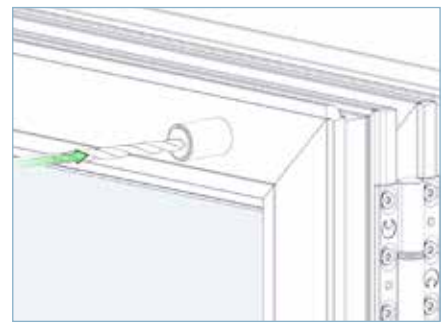

FIG 15B

## 16. Finishing touches

- ▶ **16.1** Insert fixing plugs provided into the ½” holes drilled into the jambs (after inspection, if required).
- ▶ **16.3.** We recommend you use the non or low expanding foam to fill the gaps between the outer frame and building on all 4 sides.
- ▶ **16.4.** Using silicone carefully seal along the joint between the tracks and each jamb to track connector and tool in with a suitable tool.
- ▶ **16.5.** Using silicone carefully seal each external mitre from the glass to the flat face of the door sash profile and tool in using a suitable tool

**NOTE:** The weather seal around the outer frame to the building is the responsibility of the installer. Silicone and trim kits are available from Origin.

## Installation Anchor Schedule

INSTALLATION TYPE	SECTION VIEW	FASTENER HEAD TYPE	FASTENER SIZE	SUBSTRATE	MANUFACTURER AND/OR SPECIFICATION	MIN. EMBEDMENT (IN)	MIN. EDGE DISTANCE (IN)	MIN. SPACING (IN) BETWEEN FRAME ANCHORS	ANCHOR CAPACITIES BASED ON
HEAD	DETAIL 2 (SHEET 7)	HEX HEAD	1/4"	CONCRETE	ITW TAPCONS (I)	1-1/2	1-1/2	3	MIN. 2500 PSI CONCRETE
				MASONRY (BLOCK/CMU)	ITW TAPCONS (I)	1	2	4	STRENGTH CONFORMANCE TO ASTM C-90, MEDIUM WEIGHT
SILL	DETAIL 3A, 3B & 3C (SHEETS 8 & 9)	HEX HEAD	1/4"	CONCRETE	ITW TAPCONS (I)	1-1/2	1-1/2	3	MIN. 2500 PSI CONCRETE
				MASONRY (BLOCK/CMU)	ITW TAPCONS (I)	1	3	4	STRENGTH CONFORMANCE TO ASTM C-90, MEDIUM WEIGHT
JAMBS	DETAIL 1 (SHEET 7)	PAN HEAD	1/4"	MASONRY (BLOCK/CMU)	ITW TAPCONS (I)	1	3	4	STRENGTH CONFORMANCE TO ASTM C-90, MEDIUM WEIGHT
				CONCRETE	ITW TAPCONS (I)	1-1/2	1-1/2	3	MIN. 2500 PSI CONCRETE
HEAD	DETAIL 2 (SHEET 7)	HEX HEAD	1/4"	WOOD	ANSI B18.6.1 (WOOD SCREW) (2) GRADE 2 EQUIVALENT	1-3/8	7/8	7/8	WOOD WITH A MINIMUM SPECIFIC GRAVITY OF 0.42
					ANSI B18.6.4 (TAPPING SCREW) (2) GRADE 2 EQUIVALENT	1-3/8	7/8	7/8	WOOD WITH A MINIMUM SPECIFIC GRAVITY OF 0.42
SILL	DETAIL 3A, 3B & 3C (SHEETS 8 & 9)	HEX HEAD	1/4"	WOOD	ANSI B18.6.1 (WOOD SCREW) (2) GRADE 2 EQUIVALENT	1-3/8	7/8	7/8	WOOD WITH A MINIMUM SPECIFIC GRAVITY OF 0.42
					ANSI B18.6.4 (TAPPING SCREW) (2) GRADE 2 EQUIVALENT	1-3/8	7/8	7/8	WOOD WITH A MINIMUM SPECIFIC GRAVITY OF 0.42
JAMBS	DETAIL 1 (SHEET 7)	PAN HEAD	1/4"	WOOD	ANSI B18.6.1 (WOOD SCREW) (2) GRADE 2 EQUIVALENT	1-3/8	7/8	7/8	WOOD WITH A MINIMUM SPECIFIC GRAVITY OF 0.42
					ANSI B18.6.4 (TAPPING SCREW) (2) GRADE 2 EQUIVALENT	1-3/8	7/8	7/8	WOOD WITH A MINIMUM SPECIFIC GRAVITY OF 0.42

## Installation Notes

1. PRODUCT ANCHORS SHALL BE AS DESIGNATED AND LOCATED AS SHOWN IN THIS PRODUCT EVALUATION DOCUMENT AS FOLLOWS. ANCHOR EMBEDMENT AND EDGE DISTANCE EXCLUDE WALL FINISHES, INCLUDING BUT NOT LIMITED TO STUCCO, FOAM, BRICK VENEER AND SIDING.
    - 1.1 HEAD AND SILL
      - 1.1.1 TWO ANCHORS ARE REQUIRED AT EACH INDICATED ANCHOR LOCATION SHOWN ON SHEET 6.
      - 1.1.2 AT THE FOLDING DOOR HINGE ROLLER (FORK) LOCATIONS A CLUSTERED ANCHOR SET ARE REQUIRED COMPRISED OF TWO PAIRS OF ANCHORS A 3" APART (+1" TOLERANCE)
      - 1.1.3 AT THE FOLDING DOOR HINGE LOCATIONS WITHOUT A DOOR ROLLER, ONE PAIR OF ANCHORS IS REQUIRED AT THE CENTERLINE OF THE MATING DOORS (+/-1" TOLERANCE)
      - 1.1.4 AT THE FOLDING DOOR LEAF CENTERLINE, ONE PAIR OF ANCHORS IS REQUIRED AT THE LEAF CENTERLINES (+/-1" TOLERANCE).
      - 1.1.5 AT 4" FROM THE JAMB END OF THE HEAD AND SILL FRAME, ONE PAIR OF ANCHORS IS REQUIRED (+/-1" TOLERANCE).
      - 1.1.6 SEE SHEET 7 FOR HEAD AND SILL ANCHOR DETAILS.
    - 1.2 JAMBS
      - 1.2.1 ONE ANCHOR IS REQUIRED AT EACH INDICATED ANCHOR LOCATION SHOWN ON SHEET 6.
      - 1.2.2 ONCE ANCHOR LOCATED AT THE CENTERLINE OF EACH OF THE THREE HINGE LOCATIONS IS REQUIRED (+/-1" TOLERANCE).
      - 1.2.3 ONE ANCHOR EVENLY SPACED BETWEEN THE HINGE ANCHORS IS REQUIRED (+/-1" TOLERANCE).
      - 1.2.4 A TOTAL OF 5 ANCHORS ARE REQUIRED FOR EACH JAMB SPACED AS REQUIRED ABOVE.
      - 1.2.5 SEE SHEETS 8 AND 9 FOR JAMB ANCHOR DETAILS.
  2. SEE INSTALLATION ANCHOR SCHEDULE ON SHEET 2 FOR TYPE AND GRADE OF ANCHOR, AND/OR MANUFACTURER'S ANCHOR SPECIFICATIONS, INCLUDING MINIMUM NOMINAL SIZE, MINIMUM EMBEDMENT INTO SUBSTRATE AND MINIMUM EDGE DISTANCES.
    - 2.1 EDGE DISTANCES SHALL BE MEASURED FROM CENTERLINE OF ANCHOR TO EDGE OF STRUCTURAL SUBSTRATE EITHER TO THE INTERIOR OR EXTERIOR OF THE FENESTRATION PRODUCT.
    - 2.2 MINIMUM EMBEDMENT SHALL BE BASED ON PENETRATION INTO MAIN WIND FORCE RESISTING SYSTEM SUBSTRATE.
  3. SEE SHEETS 6 THROUGH 9 FOR SPECIFIC ANCHOR INSTALLATION DETAILS.
  4. MAXIMUM ALLOWABLE SHIM THICKNESS IS ¼ INCH. SHIM WHERE SPACE OF 1/16 INCH OR GREATER OCCURS. SHIM(S) SHALL BE CONSTRUCTED OF WOOD COMPOSITE, HIGH DENSITY PLASTIC OR SIMILAR LOAD BEARING MATERIAL.
  5. FOR CONCRETE BLOCK APPLICATIONS DO NOT INSTALL INSTALLATION ANCHORS INTO MORTAR JOINTS.
  6. INSTALLATION ANCHORS SHALL BE INSTALLED IN ACCORDANCE WITH ANCHOR MANUFACTURER'S INSTALLATION INSTRUCTIONS AND ANCHORS SHALL NOT BE USED IN SUBSTRATES WITH STRENGTHS
-



Anchor location table (folding sliding door system)

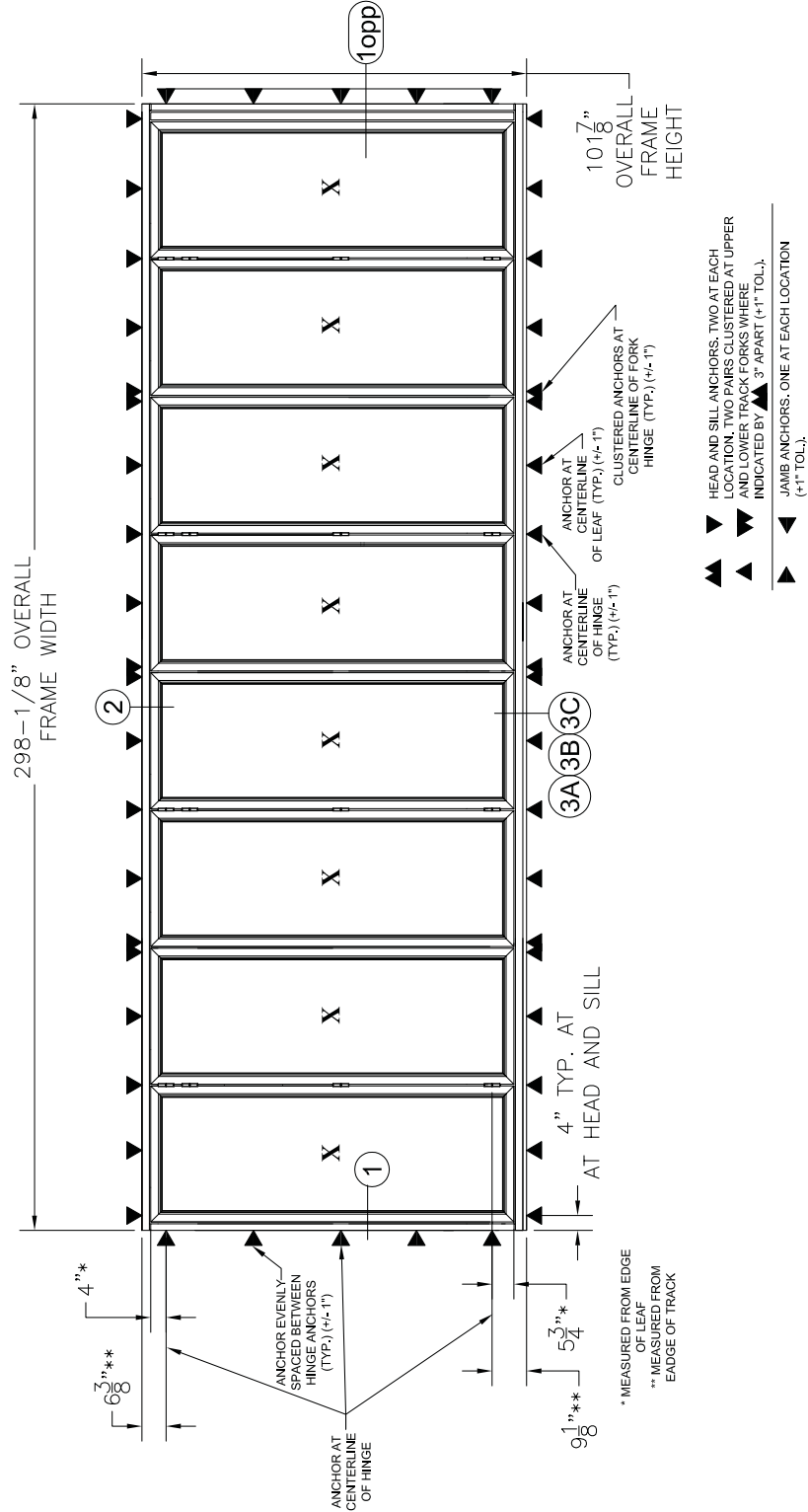

## Anchor location table (side-hinged door system)

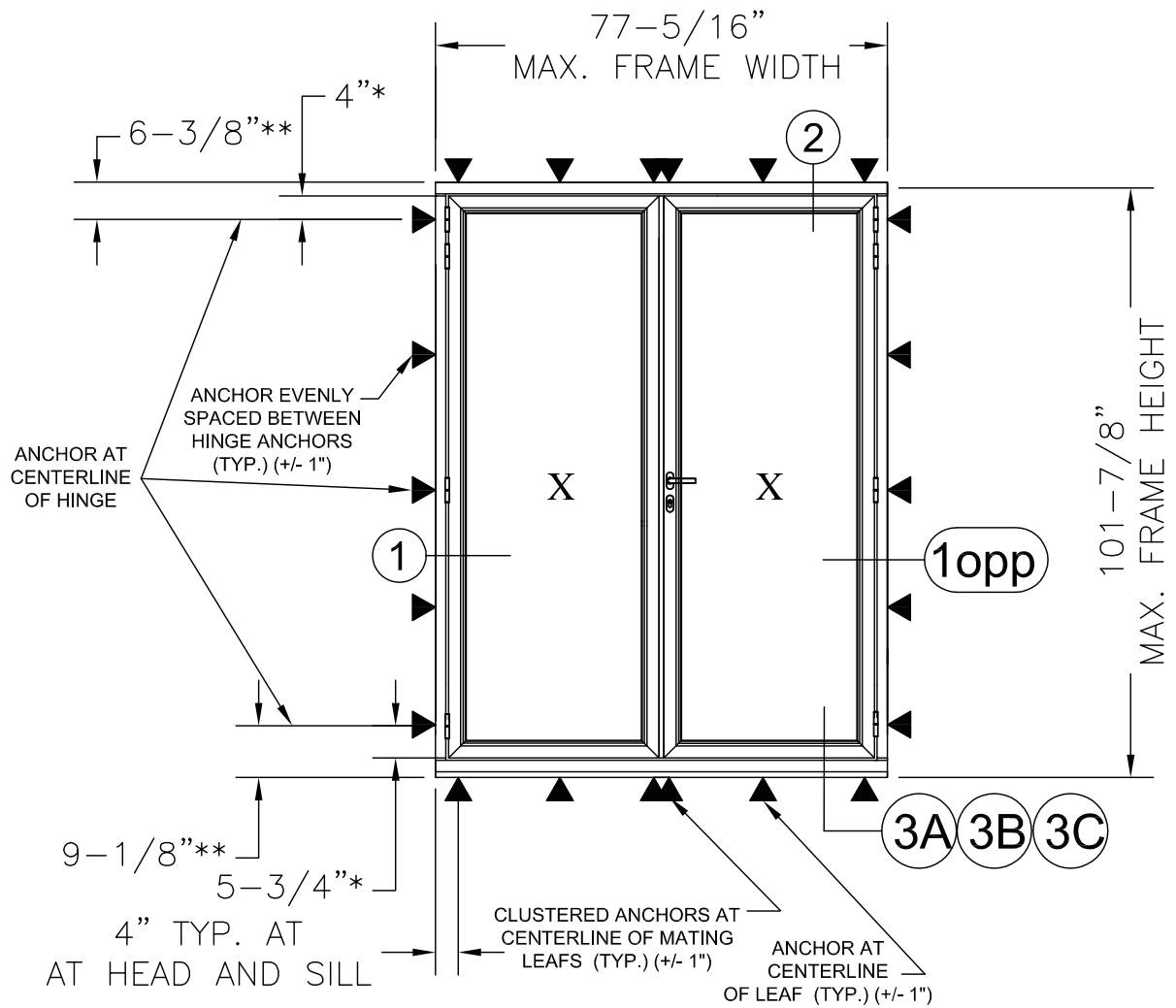

- |     |  |
|-----|--|
| ▲ ▼ | HEAD AND SILL ANCHORS. TWO AT EACH LOCATION. TWO PAIRS CLUSTERED AT UPPER AND LOWER TRACKS WHERE INDICATED BY ▲ ▼ 3" APART (+1" TOL.). |
| ▶ ◀ | JAMB ANCHORS. ONE AT EACH LOCATION (+1" TOL.).   |



Visit [www.originbifolds.com/information-for-professionals](http://www.originbifolds.com/information-for-professionals) for all technical aspects of the doors.

Alternatively, visit [www.youtube.com/user/bifoldingdoors](http://www.youtube.com/user/bifoldingdoors) to view a step-by-step video installation guide.

**origin**  
DOORS AND WINDOWS

Origin USA,  
700 Commerce Drive,  
Venice, Florida 34292

t 941-484-4970  
e [info@originbifolds.com](mailto:info@originbifolds.com)  
w [www.originbifolds.com](http://www.originbifolds.com)